

- CURRENT DATA LOGGERS

SENTINEL[®] CURRENT DATA LOGGERS



Owner's Record

The serial number for the Sentinel® Data Logger is located on the bottom side of the case. Please record this number and purchase date for your records.

SENTINEL® DATA LOGGER

MODEL #: _____

SERIAL #: _____

PURCHASE DATE: _____

DISTRIBUTOR: _____

Table of Contents

1. INTRODUCTION	3
1.1 International Electrical Symbols	3
1.2 Definition of Measurement Categories	4
1.3 Receiving Your Shipment	4
1.4 Ordering Information	4
1.5 Accessories and Replacement Parts	5
1.5.1 Sensors Compatible with Model SDL-A401	6
1.5.2 Current Probes Compatible with Model SDL-A402	6
2. PRODUCT FEATURES	8
2.1 Description	8
2.2 Control Features	9
3. SPECIFICATIONS	11
3.1 Electrical	11
3.2 Mechanical	12
3.3 Environmental	12
3.4 Safety	12
4. OPERATION	13
4.1 Operating Modes	13
4.2 Connecting the Sentinel® to a Computer	15
4.3 Turning the Unit On	15
4.4 Recording Data	16
4.4.1 Starting a Recording Session	16
4.4.2 Stopping a Recording Session	17
4.5 Downloading Recorded Data	17
4.6 Erasing Data from Memory	17
4.7 Data Storage	18
4.7.1 Trend Measurements	18
4.8 Normal Operation	18
4.8.1 Normal Operating Environment	18
4.9 Reset Button Operation	21
4.10 Synopsis of Operation	22

5. MAINTENANCE	25
5.1 Changing the Alkaline Batteries.....	25
5.2 Recharging the Batteries	25
5.3 Replacing the Rechargeable Batteries	26
APPENDIX A: TROUBLESHOOTING.....	27
APPENDIX B: GLOSSARY.....	28
Repair and Calibration.....	30
Technical and Sales Assistance	30
Limited Warranty	31
Warranty Repairs.....	31







INTRODUCTION

WARNING

These safety warnings are provided to ensure the safety of personnel and proper operation of the instrument.

- Read the instruction manual completely and follow all the safety information before attempting to use or service this instrument.
- Never exceed the maximum working voltage ratings given.
- NEVER open the back of the instrument while connected to any circuit or input.
- Always inspect the instrument accessories and leads prior to use. Replace any defective parts immediately with factory parts.

1.1 International Electrical Symbols

	This symbol signifies that the instrument is protected by double or reinforced insulation.
	This symbol on the instrument indicates a WARNING and that the operator must refer to the user manual for instructions before operating the instrument. In this manual, the symbol preceding instructions indicates that if the instructions are not followed, bodily injury, installation/sample and product damage may result.
	Risk of electric shock. The voltage at the parts marked with this symbol may be dangerous.
	This symbol refers to a type A current sensor. This symbol signifies that application around and removal from HAZARDOUS LIVE conductors is permitted.
	This symbol refers to a type B current sensor. Do not apply around or remove from HAZARDOUS LIVE conductors without additional protective means (de-energizing the circuit or wearing protective clothing suitable for high voltage work).
	In conformity with WEEE 2002/96/EC

1.2 Definition of Measurement Categories

- Cat. I:** For measurements on circuits not directly connected to the AC supply wall outlet such as protected secondaries, signal level, and limited energy circuits
- Cat. II:** For measurements performed on circuits directly connected to the electrical distribution system. Examples are measurements on household appliances or portable tools.
- Cat. III:** For measurements performed in the building installation at the distribution level such as on hardwired equipment in fixed installation and circuit breakers.
- Cat. IV:** For measurements performed at the primary electrical supply (<1000V) such as on primary overcurrent protection devices, ripple control units, or meters

1.3 Receiving Your Shipment

Upon receiving your shipment, make sure that the contents are consistent with the packing list. Notify your distributor of any missing items. If the equipment appears to be damaged, file a claim immediately with the carrier and notify your distributor at once, giving a detailed description of any damage. Save the damaged packing container to substantiate your claim.

1.4 Ordering Information

UNITS

Sentinel® AC Logger Model SDL-A301 Cat. #2134.15
(3-Channel, 1000AAC)

Includes three attached 24" AmpFlex® sensors, USB cable, DataView® CD-ROM, 4x1.5V C-cell alkaline batteries installed, user manual and warranty card.

Sentinel® AC Logger Model SDL-A302 Cat. #2134.16
(3-Channel, 3000AAC)

Includes three attached 24" AmpFlex® sensors, USB cable, DataView® CD-ROM, 4x1.5V C-cell alkaline batteries installed, user manual and warranty card.

Sentinel® AC Logger Model SDL-A303 Cat. #2134.17
(3-Channel, 1000AAC)

Includes three attached 24" AmpFlex® sensors, USB cable, (120V US) wall plug adapter with 9Vdc output, DataView® CD-ROM, 4x1.5V AA rechargeable NiMH batteries installed, user manual and warranty card.

Sentinel® AC Logger Model SDL-A304 Cat. #2134.18

(3-Channel, 3000AAC)

Includes three attached 24" AmpFlex® sensors, USB cable, (120V US) wall plug adapter with 9Vdc output, DataView® CD-ROM, 4x1.5V AA rechargeable NiMH batteries installed, user manual and warranty card.

Sentinel® DC Logger Model SDL-A401 Cat. #2134.19

(4-Channel - Four AmpFlex® Sensors w/ BNC Output [not included])

Includes USB cable, (120V US) wall plug adapter with 9Vdc output, DataView® CD-ROM, 4x1.5V AA rechargeable NiMH batteries installed, user manual and warranty card.

Sentinel® AC/DC Logger Model SDL-A402 Cat. #2134.20

(4-Channel - Four 1V Current Probes with BNC Output [not included])

Includes USB cable, (120V US) wall plug adapter with 9Vdc output, DataView® CD-ROM, 4x1.5V AA rechargeable NiMH batteries installed, user manual and warranty card.

KITS

Sentinel® AC Logger Model SDL-A401 Kit..... Cat. #2134.21

Includes the Model SDL-A401, three 1000A 24" AmpFlex® sensors with BNC output, USB cable, (120V US) wall plug adapter with 9Vdc output, DataView® CD-ROM, 4x1.5V AA rechargeable NiMH batteries installed, carrying bag, user manual and warranty card.

Sentinel® AC Logger Model SDL-A401 Kit..... Cat. #2134.22

Includes the Model SDL-A401, four 1000A 24" AmpFlex® sensors with BNC output, USB cable, (120V US) wall plug adapter with 9Vdc output, DataView® CD-ROM, 4x1.5V AA rechargeable NiMH batteries installed, carrying bag, user manual and warranty card.

Sentinel® AC Logger Model SDL-A401 Kit..... Cat. #2134.23

Includes the Model SDL-A401, three 3000A 36" AmpFlex® sensors with BNC output, USB cable, (120V US) wall plug adapter with 9Vdc output, DataView® CD-ROM, 4x1.5V AA rechargeable NiMH batteries installed, carrying bag, user manual and warranty card.

Sentinel® AC Logger Model SDL-A401 Kit..... Cat. #2134.24

Includes the Model SDL-A401, four 3000A 36" AmpFlex® sensors with BNC output, USB cable, (120V US) wall plug adapter with 9Vdc output, DataView® CD-ROM, 4x1.5V AA rechargeable NiMH batteries installed, carrying bag, user manual and warranty card.

1.5 Accessories and Replacement Parts

Set of color-coded leads (red/black) with alligator clips..... **Cat. #2118.51**

Banana (Female) - BNC (Male) Adapter (XM-BB)..... **Cat. #2118.46**

Large classic tool bag..... **Cat. #2133.71**

110/220V Power Adapter for use with
Sentinel Models A303, A304, A401 and A402 **Cat. #2134.41**

1.5.1 Sensors Compatible with Model SDL-A401

AmpFlex® SDL-1000A - 24" with BNC output.....	Cat. #2129.00
AmpFlex® SDL-1000A - 36" with BNC output.....	Cat. #2129.01
AmpFlex® SDL-3000A - 24" with BNC output.....	Cat. #2129.02
AmpFlex® SDL-3000A - 36" with BNC output.....	Cat. #2129.03

1.5.2 Current Probes Compatible with Model SDL-A402



NOTE: All current probes except Models MN261, SL261, SR661, MR461 and MR561 will require a Banana (Female) to BNC (Male) adapter [Cat. #2118.46]

AC Current Probe Model MN103 (Lead - 1mV/mA - 10A max & 1 mV/A - 100A max).....	Cat. #1031.02
AC Current Probe Model MN114 (Lead - 100mV/A - 10A max)	Cat. #2110.71
AC Current Probe Model MN251 (Lead - 1mV/A - 240A max).....	Cat. #2115.77
AC Current Probe Model MN261 (BNC - 100mV/A - 24A; 10mV/A 240A max)	Cat. #2115.82
AC Current Probe Model MN307 (Lead - 100mV/A _{AC} - 12A max)	Cat. #2116.23
AC Current Probe Model MN375 (Lead - 100mV/A - 10A max)	Cat. #2115.41
AC/DC Current Probe Model SL201 (Lead - 1mV/mA - 2A max & 1mV/A - 150A max)	Cat. #1201.40
AC/DC Current Probe Model SL206 (Lead - 1mV/mA - 2A max & 10mV/A - 80A max)	Cat. #1201.45
AC/DC Current Probe Model SL261 (BNC - 100mV/mA - 10A peak & 10mV/A - 100A peak)	Cat. #1201.51
AC Current Probe Model MD301 (Lead - 1mV _{DC} /A _{AC} - 500A max)	Cat. #1201.07
AC Current Probe Model MD314 (Lead - 1mV/A - 500A max).....	Cat. #2110.75

AC Current Probe Model SR652 (Lead - 1mV/A - 1000A max)	Cat. #2113.46
AC Current Probe Model SR661 (BNC - 100mV/A-10A; 10mV/A-100A; 1mV/A-1000A max)	Cat. #2113.49
AC Current Probe Model SR752 (Lead - 1mV/A - 1000A max)	Cat. #2116.32
AC Current Probe Model SR759 (Lead - 1/10/100/1000A/1V).....	Cat. #2116.33
AC/DC Current Probe Model MR461 (BNC - 10mV/mA - 60A peak & 1mV/A - 600A peak).....	Cat. #1200.72
AC/DC Current Probe Model MR561 (BNC - 10mV/mA - 150A peak & 1mV/A - 1500A peak)	Cat. #1200.73



NOTE: The current probe measurement ranges are limited to 1Vrms.
Above 1.1Vrms, the meter will show overload.

Order Accessories and Replacement Parts Directly Online
Check our Storefront at www.aemc.com/store for availability

PRODUCT FEATURES

2.1 Description

The Sentinel® Current Data Loggers are three- and four-channel current recording devices with alkaline or rechargeable battery packs (model dependent). Line tracking is performed such that 64 samples over one line cycle are taken. Frequency tracking is performed over the range of $\pm 3\text{Hz}$ around the nominal line frequency (50 or 60Hz). Measurements are calculated from these 64 samples for all input channels.

The Sentinel® records RMS values for each of the inputs at a rate of up to four times per second. Measurements for each channel are taken sequentially. RMS calculations from the 64 samples are performed on each single line cycle measured for each input. DC measurements are also on all voltage models and probe dependent on current models.

The main advantage of the Sentinel® logger is its ability to perform a variety of recording tasks with easy and intuitive setup from a computer using the DataView® software, which is included.

Analog information on the input is sampled and converted to a digital signal. This digital signal is processed and stored along with scale and time information. An optically isolated Universal Serial Bus (USB) port facilitates the transfer of data from internal memory to the computer for analysis.

Three LEDs on the front panel (red, yellow and green) indicate recording and memory status at a glance. User selectable storage rate, recording length and recording modes are provided.

An optically isolated Universal Serial Bus (USB) port provides the transfer of data from internal memory to the computer for analysis. Figure 2-1 shows a block diagram of the logger.

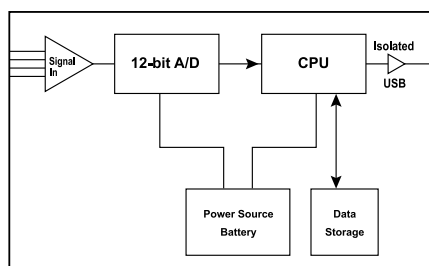

Figure 2-1. Data Logger Block Diagram

2.2 Control Features

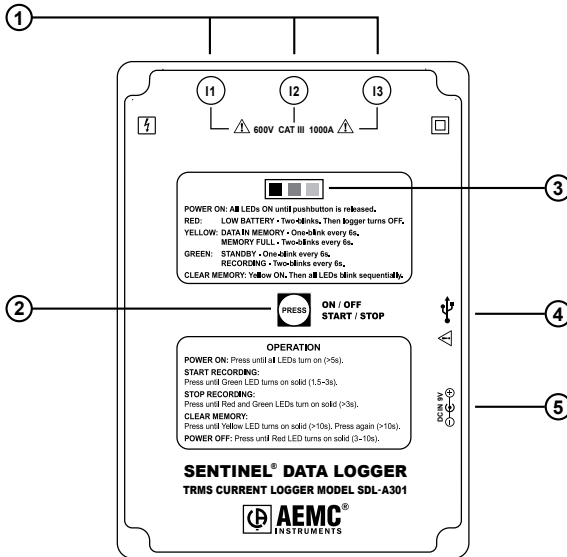

Figure 2-2. Key Components and Features

1. Hard-wired current inputs or BNC inputs for iron core current probes (3- or 4-channel and model dependent)

2. Control Button (Record Start/Stop)

This button marked “**PRESS**” selects the mode of operation. The logger has three modes: RECORD, STANDBY and OFF. Use this button to start or stop recordings and erase the memory.

3. Three LED Indicators

- **RED LED:** Indicates the status of battery voltage
- **YELLOW LED:** Indicates the status of the memory
LED OFF: No data in memory
LED Single Blink: Memory is partially filled
LED Double Blink: Memory is full
- **GREEN LED:** Indicates the mode of operation
LED OFF: Logger is turned off
LED Single Blink: Logger is in Standby Mode (and not recording)
LED Double Blink: Logger is in Record Mode



Note: All LEDs single blink simultaneously in case of an overload ($\geq 10\%$ above range) at the input if the unit is in power-on status.

4. **USB Communication Port**

5. **Power Input** (Model dependent)

6. **Reset Button (not shown)**

This button resets the CPU.

The **RESET** Button is located inside the instrument under the shield. Remove the rear cover and insert a small tool, such as a pen, through the hole in the shield to activate it. **Do not** press the **RESET** Button under normal operation.



WARNING: If the **RESET** Button is pressed when the logger is recording, it will stop recording and data in the memory may be lost.

SPECIFICATIONS

3.1 Electrical

Reference Conditions: 23°C ± 5°C (30 to 50% RH) range. Add 300 ppm/°C from -10° to 18°C and 28° to 50°C to all accuracy specifications. Conductor must be centered in the sensor. Continuous magnetic field <40 A/m (Earth Magnetic Field). No external electrical or alternating magnetic field is present. Sinusoidal current with frequency 50/60Hz ± 3Hz for >60A and 50/60Hz for <60A. Calibration cycle is 1 year.

MODEL	SDL-A301	SDL-A302
Channels	Three	Three
Input	Hard-wired AmpFlex® Flexible Current Sensors	
Current Range	5 to 1000A	15 to 3000A
Resolution	0.1A	0.25A
Accuracy	5 to 100A: ± (1.0% of Reading + 1.2A) 100 to 1000A: ± (1.0% of Reading + 1.0A)	15 to 100A: ± (1.0% of Reading + 1.5A) 100 to 3000A: ± (1.0% of Reading + 1.0A)
Sample Rate	64 samples/cycle	
Storage Rate	Programmable from 250ms to 12 hrs	
Storage Technique	Stop when full, FIFO and Extended Recording Mode* (XRM™)	
Recording Length	1 minute to 8 weeks, programmable using DataView®	
Memory	480,000 measurement (1MB)	
Communication	USB 2.0 optically isolated	
Power Source**	4x1.5V C-cell alkaline batteries	
Battery Life	100 hours to 45 days (dependent on sample rate)	

MODEL	SDL-A303	SDL-A304
Channels	Three	Three
Input	Hard-wired AmpFlex® Flexible Current Sensors	
Current Range	5 to 1000A	15 to 3000A
Resolution	0.1A	0.25A
Accuracy	5 to 100A: ± (1.0% of Reading + 1.2A) 100 to 1000A: ± (1.0% of Reading + 1.0A)	15 to 100A: ± (1.0% of Reading + 1.5A) 100 to 3000A: ± (1.0% of Reading + 1.0A)
Sample Rate	64 samples/cycle	
Storage Period	Programmable from 250ms to 12 hrs	
Storage Technique	Stop when full, FIFO and Extended Recording Mode* (XRM™)	
Recording Length	1 minute to 8 weeks, programmable using DataView®	
Memory	480,000 measurement (1MB)	
Communication	USB 2.0 optically isolated	
Power Source**	AC power/rechargeable 4x1.5V NiMH battery pack	
Battery Life	Power ride through 10 hrs	

MODEL	SDL-A401		SDL-A402
Channels	Four		Four
Input	BNC		
Sensor/Probe Type	24" or 36" AmpFlex® Flexible Current Sensors		0-1V output probes w/BNC (use only specified current probes)
Current Range	5 to 1000A	15 to 3000A	Probe dependent
Resolution	0.1A	0.25A	Probe dependent
Accuracy	5 to 100A ± (1.0% of Reading +1.2A)	15 to 100A ± (1.0% of Reading +1.5A)	Probe dependent
	100 to 1000A ± (1.0% of Reading +1.0A)	100 to 3000A ± (1.0% of Reading +1.0A)	
Sample Rate	64 samples/cycle		
Storage Rate	Programmable from 0.25s to 12 hrs		
Storage Technique	Stop when full, FIFO and Extended Recording Mode* (XRM™)		
Recording Length	1 minute to 8 weeks, programmable using DataView®		
Memory	480,000 measurement (1MB)		
Communication	USB 2.0 optically isolated		
Power Source**	AC power/rechargeable 4x1.5V NiMH battery pack		
Battery Life	Power ride through 10 hrs		

*This unique recording mode provides the opportunity to continuously record over long periods of time by reducing the stored sample resolution of the oldest data and maintaining matching resolution for the newest data. Each time the memory fills up using XRM™, every other of the oldest stored samples is discarded making room for newer samples. This process continues until the recording is manually stopped.

**An internal lithium battery (>2.8V) provides additional memory back up for up to 30 days. If the unit is connected to DataView® via a PC, the operating time is 100 hours regardless of the storage rate.

3.2 Mechanical

Dimensions: 6.73 x 4.76 x 2.17" (171 x 121 x 55mm)

Weight - Models A301-A302-A303-A304: 3 lbs (1.4kg) with batteries and probes

Weight - Model A401: 3.3 lbs (1.5kg) with batteries and probes

Weight - Model A402: 1.1 lbs (0.5kg) with batteries, excluding probes

Case: Polycarbonate UL94-V2

Vibration: IEC 68-2-6 (1.5mm 10 to 55Hz)

Shock: IEC 68-2-27 (30G)

Drop: IEC 68-2-32 (1m)

3.3 Environmental

Operating Temperature: 14° to 122°F (-10° to 50°C)

Storage Temperature: -4° to 140°F (-20° to 60°C)

Relative Humidity: 0 to 85% @ 95°F (35°C), Non-condensing

Altitude: 2000m

3.4 Safety

Safety: 600V Cat. III, 300V Cat. IV (with sensors/probes attached)

*All specifications are subject to change without notice

OPERATION

4.1 Operating Modes

The Sentinel® Data Logger has three modes of operation: RECORD, STANDBY and OFF.

After the instrument has been turned on, the operating mode of the logger can be determined by pressing the **PRESS** button for less than 1.5 seconds.

The GREEN LED indicates the mode of operation:

LED OFF: Logger is turned off

LED Single Blink: Logger is in Standby Mode (and not recording)

LED Double Blink: Logger is in Record Mode

The YELLOW LED indicates the state of recording memory:

LED OFF: No data in memory

LED Single Blink: Memory is partially filled

LED Double Blink: Memory is full

In the STANDBY and OFF modes, the logger retains recorded information for transfer to a computer.

Both of these modes have low power states, which require very little power from the battery. The LEDs will not blink at this time. By using these low power states the instrument can be programmed to start recording at some time in the future without draining the batteries. The instrument can also record for very long periods.



NOTE: While in a low power state, a button press is required before further use of the instrument. For this reason, a short button press should be issued before attempting any button control operations.

When in the STANDBY mode, the unit enters the low power state if the button is not pressed for five minutes. It will remain in this state until either the button is pressed or the internal clock reaches the start time for a scheduled recording.

When in the RECORD mode, the instrument will enter the low power state provided the storage period is one second or greater and the button has not been pressed for five minutes. If the recording storage rate is faster than once per second the unit will not power down between sample sets.

Operations are determined by the length of time the control button is pressed. The lighting of each LED in sequence provides a visual indication that a required amount of time (for each operation) has been reached.

The following table illustrates the operations that can be performed while in each of the three modes.

Mode	Operation to be Performed	Press Duration (seconds)	Indication (LEDs that light)	Notes
Off	Turn On	5	RED, GREEN and YELLOW simultaneously	(1)
Standby	Turn Off	5	GREEN, then RED	(2) (3)
	Start Recording	1.5	GREEN	
	Erase Memory	10	GREEN, then RED, then YELLOW	(2) (4) (5)
Recording	Stop Recording	3	GREEN and RED simultaneously	(1)

Notes:

- (1) LEDs light at the same time.
- (2) LEDs light one at a time in sequence.
- (3) GREEN lights after 1.5 seconds, RED lights after 3 s.
- (4) GREEN lights after 1.5 seconds, RED lights after 3 seconds and YELLOW lights after 10 s.
- (5) Hold the button for 10 seconds. Release it. Press again within 3 seconds and hold for 10 s.



NOTE: If the input to the logger exceeds 10% over the measurement range and the logger is powered on, all three LEDs will blink at a rate of one per second.

4.2 Connecting the Sentinel® to a Computer



INSTALL THE DATAVIEW® SOFTWARE BEFORE INSTALLING THE USB DRIVERS AND BEFORE CONNECTING THE SENTINEL® TO THE COMPUTER.

Figure 4-1 shows a typical hook-up. The Sentinel® Data Logger utilizes an optically isolated USB communication port.

The manual for the computer should indicate where to find the USB port on your computer.

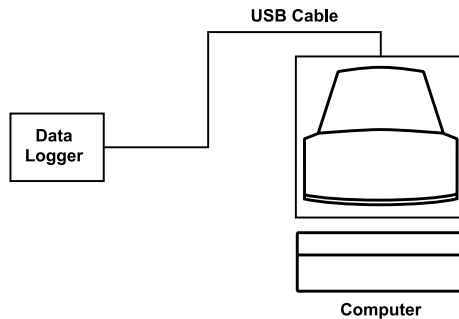

Figure 4-1

The logger can be connected to the computer during a recording session, however, additional battery drainage will occur to support the active USB connection.

4.3 Turning the Unit On

The Sentinel® Data Logger can be turned ON by performing one of the following:

- Press and hold the **PRESS** button for approximately 5 seconds.
- Connect the unit to a USB port on your computer and establish communication with the instrument using the DataView® software. The logger will remain ON while a communication link with DataView® is active (provided sufficient battery power is available during the communication session).

The unit has been turned ON successfully when the RED, YELLOW and GREEN LEDs light up. At this time you can release the **PRESS** button.

The unit is now in the STANDBY mode.

The instrument contains protection circuitry to prevent it from being turned on when the battery voltage is below 3.8V.

There are two thresholds for the battery voltage depending on how the instrument is turned ON (either button press or DataView®) and the recording state that it is in.

- **If the unit is turned ON from a button press, the threshold is 4.3V.**
This means that if the unit is turned on and the battery voltage is below 4.3V, the RED LED will double-blink and the unit will turn off.
- **If the unit is turned ON via DataView®, the threshold is 3.8V.**
This means that the instrument can be turned on via DataView® as long as the battery voltage is above 3.8V. If the instrument is recording, it will continue to record until the battery voltage falls below 3.8V.

4.4 Recording Data



NOTE: The Sentinel® Data Logger is factory configured and may be altered to fit the users needs (see the Configuring the Sentinel® Data Logger section inside the DataView® user manual).

Once a configuration is written to the Sentinel®, the logger will no longer need to be connected to DataView® to start the configured recording.

When data is stored in the memory, the user may download the information onto a hard-disk (see the *Downloading Recorded Instrument Data* section inside the DataView® user manual).

4.4.1 Starting a Recording Session

NOTE: A new recording cannot be started if the memory is full.

1. Connect the inputs to the measurement source.
2. Make sure the logger is in STANDBY mode (GREEN LED single-blinks).
3. Press the **PRESS** button for longer than 1.5s but less than 3s to start recording.
4. Verify that the GREEN LED double-blinks to ensure that the logger is recording.



WARNING: If during a recording the GREEN LED remains ON, the Sentinel® Data Logger is in a fault condition. Disconnect immediately (the logger will not record and the battery will drain faster).

4.4.2 Stopping a Recording Session

1. Push the **PRESS** button for >3s and <5s. The RED and GREEN LED will turn on simultaneously.
2. The GREEN LED will change from a double-blink to a single-blink, indicating STANDBY mode.

The data will be retained, even if the instrument is turned OFF. The recorded data may be downloaded to a hard-disk.

4.5 Downloading Recorded Data

Recorded measurements stored in the instrument are transferred to a database on a hard-disk via the download command in the Sentinel Control Panel. For complete instructions on downloading data, see the *Downloading Recorded Instrument Data* section inside the Sentinel DataView® user manual.

4.6 Erasing Data from Memory

Erasing data from the instrument's memory can only be performed while in the STANDBY mode.



WARNING: Data will be permanently lost by performing this procedure.

There are two ways to erase the memory:

Erasing the Memory using the **PRESS** Button:

1. Press and hold the **PRESS** button for >10s. This will arm the instrument for an erase operation (when not in record mode).
2. Once the button has been held long enough to arm the unit, the YELLOW LED will light. At this time you can release the **PRESS** button.
3. Press and hold the **PRESS** button for another 10s within 3 seconds of arming the erase operation.
4. Once the button has been held long enough to erase memory, the YELLOW LED will light. At this time you can release the **PRESS** button.
5. As the memory is being erased the unit will cycle through the three LEDs until the operation has finished.

Erasing the Memory using DataView®:

1. Connect the Sentinel to the computer and open the **Control Panel** for the Sentinel.
2. Select **Erase Memory** from the **Instrument Menu**.

4.7 Data Storage

The logger captures Trend measurements.

Input Channel: Source for the measurement channel of the instrument.

Measurement Channel: Measurement of input. This can be a simple direct measurement, the result of complex mathematical operations on a single or multiple input, or other channels.

Sample Rate: The rate at which the instrument measures inputs.

Storage Period: The period at which channel measurements are stored.

4.7.1 Trend Measurements

The Logger captures RMS calculation on each of the inputs. In addition, the user can define up to four channels, the storage rate, recording period and measurement format using the **Configure Instrument** window. Trend measurements are stored at this fixed storage rate.

4.8 Normal Operation

Following is a detailed description of the logger operation.

4.8.1 Normal Operating Environment

When the instrument is turned ON, the following occurs (provided there is sufficient battery voltage and no data is stored in the instrument's memory):

- The GREEN LED single-blinks.
(STANDBY mode is active and the logger is not recording)
- The YELLOW LED is OFF indicating there is no data in memory.
- The GREEN LED single-blinks once per second: a recording is scheduled to begin.
- The GREEN LED single-blinks once every six seconds: a recording is not scheduled to begin.

- The **PRESS** button is used to Start and Stop a Recording Session.
- If the **PRESS** button is not pressed for a period of five minutes the instrument will enter a low power STANDBY mode and wait for either another button press or the recording start time to arrive (if a recording is scheduled). While in the low power STANDBY mode the LEDs will not blink. A button press of less than 1.5 seconds will return the unit back to the normal STANDBY mode.

Event: Recording with Memory Cleared

When a recording starts, the logger will continue to record until one of the following occurs:

- The Session is complete.
- The Memory is full and the recording mode is normal (Start/Stop mode).
- The **PRESS** button is pushed again for >3s.
- The Stop Recording command from the Sentinel Control Panel is sent to the unit.
- The battery voltage falls below 3.8V.

Event: Recording with a Partial or Full Memory

If the YELLOW LED is double-blinking, the memory must be cleared before any further recording can be performed.

If the YELLOW LED is single-blinking prior to starting a New Recording Session, the memory is partially full.

To save, clear or check memory availability, use the DataView® software. There may be instances where the GREEN LED is also double-blinking indicating that the logger is still recording. The user can choose to stop the Recording Session and download the saved session(s) or clear the memory.



NOTE: The logger memory cannot be erased while in the Record mode. The recording must be stopped first by either pressing the **PRESS** button or from the software.

Event: Memory Filled During Recording Session

If the logger is recording using the normal (Start/Stop) mode and memory is filled before the Recording Session has finished, the session will end.

The following happens:

- The YELLOW LED will double-blink.
- The GREEN LED will single-blink.

At this time:

- The memory can be downloaded and cleared.
- A new recording can be started or scheduled once the memory is cleared.

Event: Battery Power is Insufficient for a Full Recording Duration

If the battery voltage drops below the threshold, the following will occur:

- The Recording Session will terminate.
- The Data will be saved.
- The GREEN and YELLOW LED will turn OFF.

The logger continues to record until the battery voltage drops to 3.8V. Pressing the **PRESS** button may not turn the unit ON at all. The battery voltage may rise slightly after the unit turns itself off. In this event, the unit may turn on momentarily as a result of a button press, the RED LED will double-blink and the unit will then turn OFF.

The batteries must be replaced before the recorded session(s) can be downloaded from the instrument.



NOTE: Replacing the batteries while the unit is OFF will not result in the loss of data memory. The internal Lithium battery will maintain the contents of memory while the main batteries are being replaced.

Event: Recording Session has Ended

The logger will be in STANDBY mode, if one of the following occurs:

- The Recording Session terminates due to recording end time being reached when recording in the Start/Stop mode.
- The recording in Start/Stop mode fills the memory.
- The user terminates the Recording Session by pressing the **PRESS** button for >3s or issues a Stop Recording command from the Sentinel Control Panel.

Under these conditions, it is possible to turn the logger ON from the computer to download the data, if the batteries have sufficient power.

The logger is now ready for a New Session or Download. Pressing the **PRESS** button for more than 1.5 seconds but less than 3 seconds will start a New Session depending on the available memory.

4.9 Reset Button Operation

There is a recessed **RESET** button located inside the unit and indicated by a label on the shield.



NOTE: It is recommended to only press the **RESET** button when the logger stops responding to a normal press button control when not connected to DataView®. It is not recommended to reset the instrument when the logger is recording, downloading or being configured.

Pressing the **RESET** button when the logger is ON will cause the instrument to reset its configuration to factory defaults. The **RESET** button should only be pressed as a last resort.



WARNING: In an effort to preserve recorded memory, the instrument's memory will be marked as full when the **RESET** occurs.

Download any desired session, then erase the memory before starting a new recording.

Event: Pressing the RESET Button while Recording (not recommended)

- The RED LED remains OFF.
- The recording session ends and the GREEN LED changes from a double-blink to a single-blink.
- The YELLOW LED double-blinks to indicate that the memory is full.

Event: Pressing the RESET Button when a Recording has Ended

- The RED LED will remain OFF.
- The GREEN LED single-blinks.
- The unit indicates that the memory is full (double-blinking YELLOW).

Event: The Logger is Waiting for a New Recording Session

If the **RESET** button is pressed when a recording has been scheduled, the logger will not start recording at the previously programmed date and time.

The unit indicates that memory is full (double-blinking YELLOW).



NOTE: The resumption of the logger operation in the above situations assumes that the Reset button cleared the fault(s). The Logger will not resume normal operation if the fault condition still exists.

4.10 Synopsis of Operation

#	Battery Voltage	Recording Session	Saved Data or Session(s) in Memory	Indicators ON, OFF			Comments Note: P/B = Press Button
				1 - Single-Blink	2 - Double-Blink		
1	>3.8V	Active	Yes	R	Y	G	P/B Stops Recording. Pushing >10s does not erase the memory during Recording. RESET resets the unit to factory default.
				OFF	1	2	
2	>3.8V	Active	No	OFF	OFF	2	P/B Stops Recording. Pushing >10s does not erase the memory during Recording. RESET resets the unit to factory default.
3	>3.8V	Inactive	Yes	OFF	1	1	P/B Starts New Session. Pushing again Stops it. If pushed >10s twice, clears the memory. RESET resets the unit to factory default.
4	>3.8V	Inactive	No	OFF	OFF	1	P/B Starts New Session. Pushing again Stops it. If pushed >10s twice, clears the memory. RESET resets the unit to factory default.
5	<3.8V	Inactive	Yes	OFF	OFF	OFF	If the battery voltage is less than 3.8V, the P/B will have no effect.

Turning the Unit On

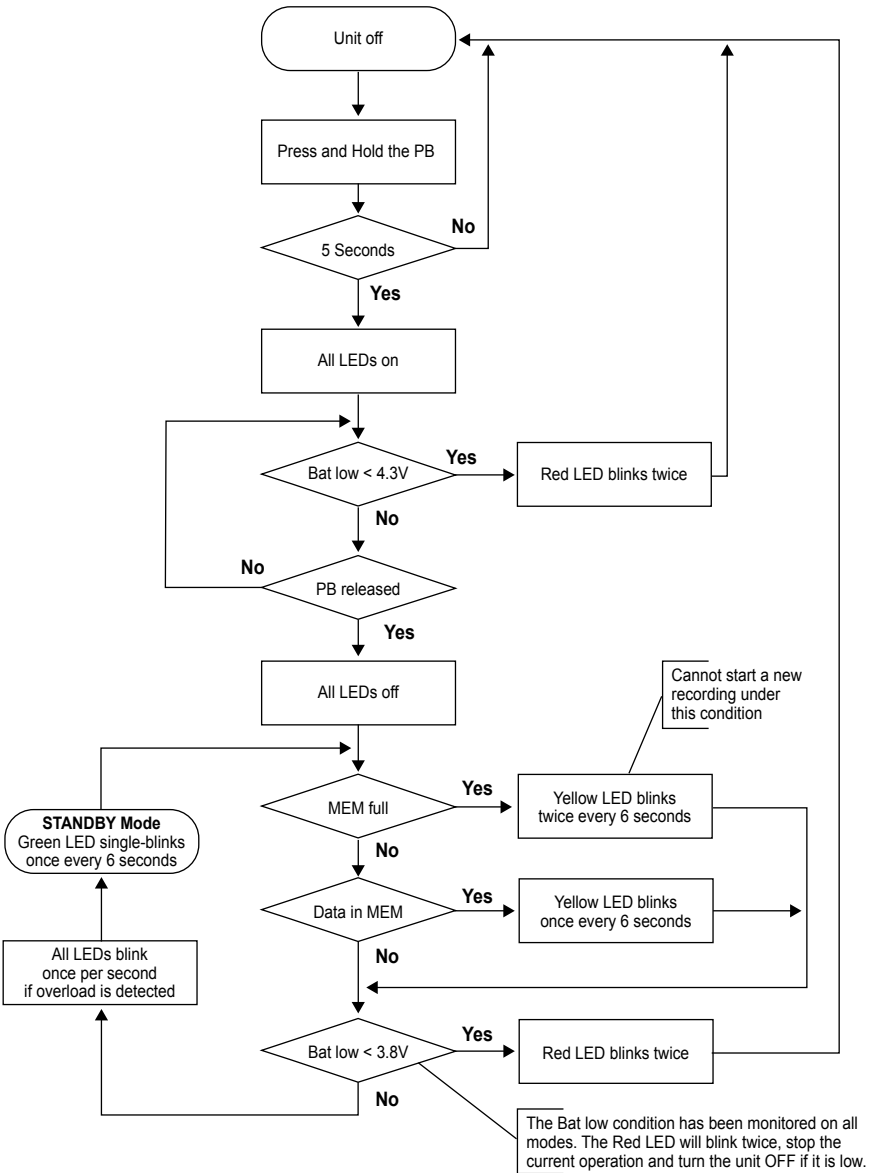

Figure 4-2

Normal Operation

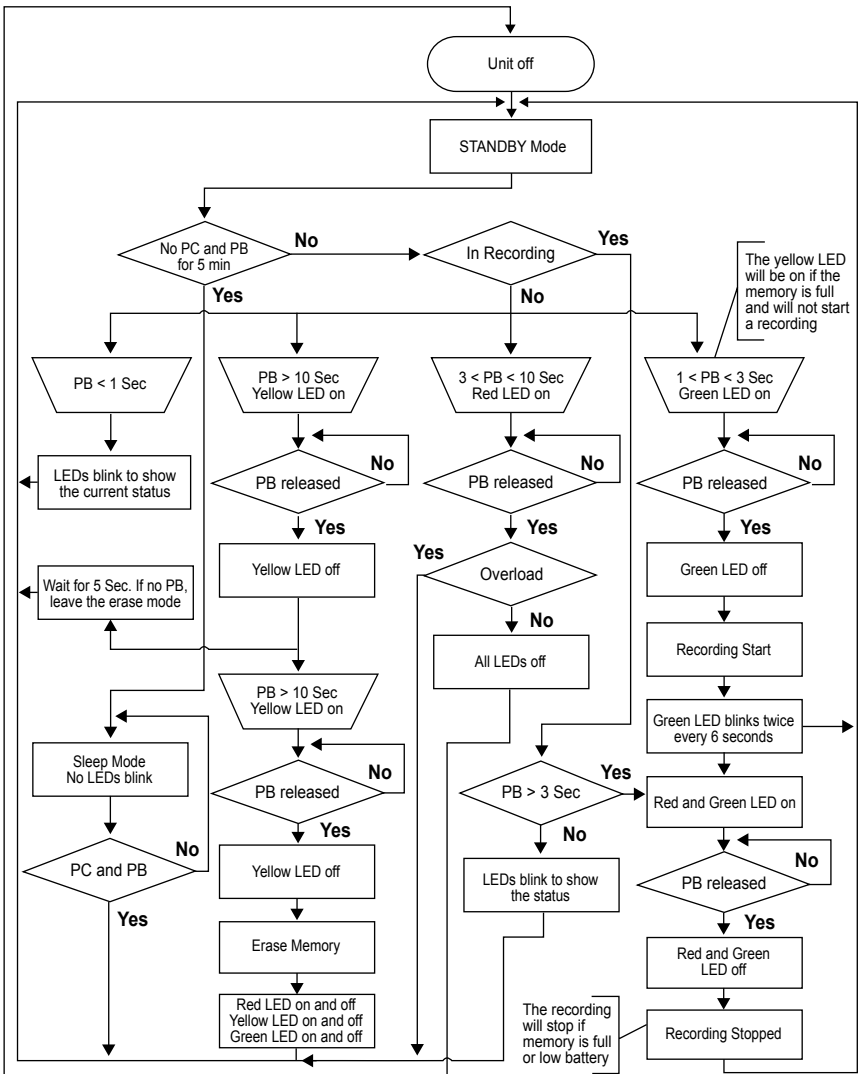

Figure 4-3

MAINTENANCE

Use only factory specified replacement parts. AEMC® will not be held responsible for any accident, incident, or malfunction following a repair done other than by its service center or by an approved repair center.

5.1 Changing the Alkaline Batteries



WARNING: Turn the unit off before changing the batteries or loss of recorded data may occur.



WARNING: Disconnect the unit from any voltage measurement points before opening the rear cover to change the batteries.

1. Remove the four screws holding the back cover on.
2. Locate/remove the screw holding the cover on the battery holder.
3. Slide cover off to remove.
4. Replace with only 1.5V C-cell alkaline batteries.
5. Replace the battery cover.
6. Press the **PRESS** button for 5 sec or longer to turn the Sentinel ON.

NOTE: It is recommended to store the unit with the batteries in it to preserve the lithium battery.

5.2 Recharging the Batteries

Plug the AC wall adapter, that was supplied with the unit, from a 120V US standard wall outlet to the power input adapter on the right side of the unit.

It is recommended that the batteries be replaced every two years.

5.3 Replacing the Rechargeable Batteries



WARNING: Disconnect all inputs and AC wall adapter before proceeding

1. Remove the four screws holding the back cover on.
2. Locate/remove the screw holding the cover on the battery holder.
3. Slide cover off to remove.
4. Replace with only 1.2V 1600mAh NiMH AA batteries.
5. Replace the battery cover.
6. Press the **PRESS** button for 5 sec or longer to turn the Sentinel ON.



NOTE: In rare cases, you may need to press both the **PRESS** button and **RESET** button at the same time to generate a system reset manually to power up the Sentinel® properly. Pressing just the **RESET** button alone immediately after the battery replacement will not work.

Once the Sentinel® turns ON and the lights start blinking, you can press the **RESET** button alone without the need for pressing the **PRESS** button to generate a system reset.



WARNING: Pressing the **RESET** button can result in the loss of recorded data. At a minimum, the unit will be reset to its factory default configuration and the memory will need to be erased before a recording can start. **The RESET button should only be pressed as a last resort.**

An additional Lithium battery cell is used to add extra protection to the recorded memory, in the event the main battery pack discharges. It also provides backup while the main batteries are being changed. This battery should be replaced once every two years. The Lithium battery is hard wired to the instrument circuit board and only the factory should replace it.

TROUBLESHOOTING

Symptom: After being in a damp, cold environment, the logger does not function.

Cause, Correction: Condensation may have formed inside the logger, shorting out the circuitry and discharging the battery. Allow the circuit board to dry thoroughly in a warm location.

Symptom: Sentinel® Data Logger does not start recording when the button is pressed.

Cause, Correction: Make sure battery power is present. Make sure you are pushing the button longer than 5 seconds to turn it ON. Make sure the YELLOW LED is not double blinking. If it is, memory is full and you need to erase the data by pushing the Record button longer than 10 seconds twice. Make sure the Sentinel® Data Logger is properly configured so that you have Storage Rate, Recording Period and at least one Measurement Channel specified.

Symptom: Sentinel® Data Logger does not respond to a button press even with fresh batteries installed.

Cause, Correction: Make sure that the instrument is not OFF. Press the button for a short duration (less than 1.5 seconds). If the LEDs do not flash then the instrument is OFF. Turn the instrument ON by pressing the control button for five seconds. The LEDs will light solid once the instrument has turned on and you may release the button at that time.

Refer to the Troubleshooting section, located in the Help menu from within the Sentinel Control Panel (in DataView®), for a complete list of issues and solutions.

GLOSSARY

Some general terminology associated with the data collection process is listed here for convenience.

Bps: Bits Per Second, a unit of signal transfer speed equal to the number of elements per second. The Sentinel® Data Logger transfers data at the rate of 115200 bps.

Bi-Polar Inputs: The ability to accept both + and - inputs.

Button: An actual key on the logger or computer keyboard or a soft key in the program on the computer screen.

CMRR: Common Mode Rejection Ratio; the ability to measure only the difference between the input leads, rejecting what the leads have in common.

Cursor: A pointer or cross-hair that indicates the active position on the computer screen. It is usually moved around with the mouse or arrow keys.

Data logger: A device used to sample and store electrical signals representative of physical phenomena such as temperature, pressure and flow, for long periods of time in an unattended environment.

Download: The process of transferring data from the logger to the computer.

Hz: Hertz, a unit of measure of frequency equivalent to cycles per second.

I/O: Input/output, a device or port capable of sending or receiving digital information.

Pointer: See cursor

Port: A name given to any connector allowing input or output of information.

Processor: A computing device used to calculate and run a set of instructions.

Recording session: A recording session is defined as the time and data contained within the starting and ending of a recording.

Resolution: The number of bits in which digitized values will be stored. The Sentinel® Data Logger has 12-bit resolution.

Ride-through: Time during which the AC line voltage has dropped sufficiently low to not be able to power the instrument.

Zoom: The ability to select a section of the graph and magnify it for better readability.

USB: Universal Serial Bus, a communications port used to access the Data Logger via a computer program (Dataview®).

Repair and Calibration

To ensure that your instrument meets factory specifications, we recommend that it be scheduled back to our factory Service Center at one-year intervals for recalibration, or as required by other standards or internal procedures.

For instrument repair and calibration:

You must contact our Service Center for a Customer Service Authorization Number (CSA#). This will ensure that when your instrument arrives, it will be tracked and processed promptly. Please write the CSA# on the outside of the shipping container. If the instrument is returned for calibration, we need to know if you want a standard calibration, or a calibration traceable to N.I.S.T. (Includes calibration certificate plus recorded calibration data).

Ship To: Chauvin Arnoux®, Inc. d.b.a. AEMC® Instruments
15 Faraday Drive
Dover, NH 03820 USA
Phone: (800) 945-2362 (Ext. 360)
(603) 749-6434 (Ext. 360)
Fax: (603) 742-2346 or (603) 749-6309
E-mail: repair@aemc.com

(Or contact your authorized distributor)

Costs for repair, standard calibration, and calibration traceable to N.I.S.T. are available.

NOTE: You must obtain a CSA# before returning any instrument.

Technical and Sales Assistance

If you are experiencing any technical problems, or require any assistance with the proper operation or application of your instrument, please call, mail, fax or e-mail our technical support team:

Chauvin Arnoux®, Inc. d.b.a. AEMC® Instruments
200 Foxborough Boulevard
Foxborough, MA 02035 USA
Phone: (800) 343-1391
(508) 698-2115
Fax: (508) 698-2118
E-mail: techsupport@aemc.com
www.aemc.com

NOTE: Do not ship Instruments to our Foxborough, MA address.

Limited Warranty

The Sentinel® Data Logger is warranted to the owner for a period of one year from the date of original purchase against defects in manufacture. This limited warranty is given by AEMC® Instruments, not by the distributor from whom it was purchased. This warranty is void if the unit has been tampered with, abused or if the defect is related to service not performed by AEMC® Instruments.

For full and detailed warranty coverage, please read the Warranty Coverage Information, which is attached to the Warranty Registration Card (if enclosed) or is available at www.aemc.com. Please keep the Warranty Coverage Information with your records.

What AEMC® Instruments will do:

If a malfunction occurs within the one-year period, you may return the instrument to us for repair, provided we have your warranty registration information on file or a proof of purchase. AEMC® Instruments will, at its option, repair or replace the faulty material.

**REGISTER ONLINE AT:
www.aemc.com**

Warranty Repairs

What you must do to return an Instrument for Warranty Repair:

First, request a Customer Service Authorization Number (CSA#) by phone or by fax from our Service Department (see address below), then return the instrument along with the signed CSA Form. Please write the CSA# on the outside of the shipping container. Return the instrument, postage or shipment pre-paid to:

Ship To: Chauvin Arnoux®, Inc. d.b.a. AEMC® Instruments
15 Faraday Drive • Dover, NH 03820 USA
Phone: (800) 945-2362 (Ext. 360)
(603) 749-6434 (Ext. 360)
Fax: (603) 742-2346 or (603) 749-6309
E-mail: repair@aemc.com

Caution: To protect yourself against in-transit loss, we recommend you insure your returned material.

NOTE: You must obtain a CSA# before returning any instrument.

Notes:



05/07

99-MAN 100290 v8