

AC Current Probe

Models MN352 and MN353

User Manual

DESCRIPTION

The MN352/353 (Catalog #2116.26 and #2116.27) are the latest in compact AC current probes. Designed to meet the most stringent demands in industry and electrical contracting, they also meet the latest safety and performance standards. The probes have a measurement range up to 240 Arms which make them perfect tools for measurements with DMMs, recorders, power and harmonic meters. The Models MN352/MN353 are compatible with any AC voltmeter, multimeter, or other voltage measurement instrument that is capable of displaying 10mV of output per amp of measured current, an accuracy of 0.75% or better and an input impedance of $\geq 1 \text{ M}\Omega$.

WARNING

These safety warnings are provided to ensure the safety of personnel and proper operation of the instrument.

- Read the instruction manual completely and follow all the safety information before attempting to use or service this instrument.
- Use caution on any circuit: Potentially high voltages and currents may be present and may pose a shock hazard.
- Read the safety specifications section prior to using the current probe. Never exceed the maximum voltage ratings given.
- Safety is the responsibility of the operator.
- ALWAYS connect the current probe to the display device before clamping the probe onto the sample being tested.
- ALWAYS inspect the instrument, probe, probe cable, and output terminals prior to use. Replace any defective parts immediately.
- NEVER use the current probe on electrical conductors rated above 600V. Use extreme caution when clamping around bare conductors or bus bars.

INTERNATIONAL ELECTRICAL SYMBOLS



This symbol signifies that the current probe is protected by double or reinforced insulation. Use only factory specified replacement parts when servicing the instrument.



This symbol signifies CAUTION! and requests that the user refer to the user manual before using the instrument.



This is a type A current sensor. This symbol signifies that application around and removal from HAZARDOUS LIVE conductors is permitted.

DEFINITION OF MEASUREMENT CATEGORIES

- Cat. I:** For measurements on circuits not directly connected to the AC supply wall outlet such as protected secondaries, signal level, and limited energy circuits.
- Cat. II:** For measurements performed on circuits directly connected to the electrical distribution system. Examples are measurements on household appliances or portable tools.
- Cat. III:** For measurements performed in the building installation at the distribution level such as on hardwired equipment in fixed installation and circuit breakers.
- Cat. IV:** For measurements performed at the primary electrical supply (<1000V) such as on primary overcurrent protection devices, ripple control units, or meters.

RECEIVING YOUR SHIPMENT

Upon receiving your shipment, make sure that the contents are consistent with the packing list. Notify your distributor of any missing items. If the equipment appears to be damaged, file a claim immediately with the carrier and notify your distributor at once, giving a detailed description of any damage.

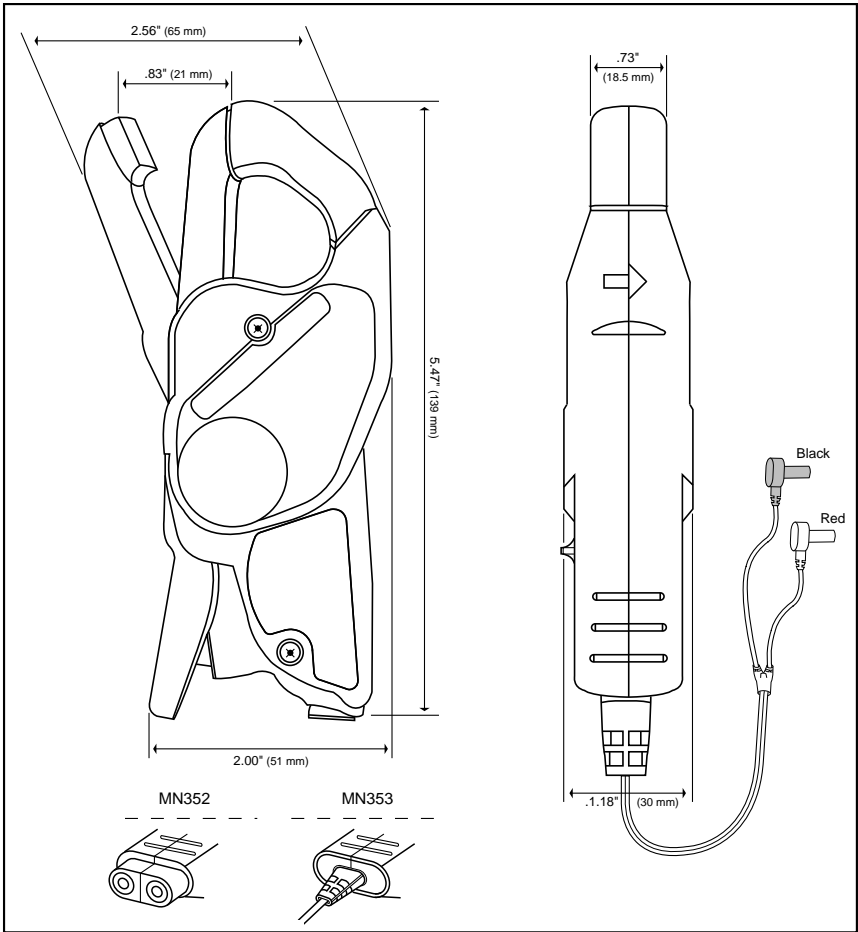

ELECTRICAL SPECIFICATIONS

Nominal Range: 200A

Measurement Range: 0.1 to 240A

Transformation Ratio: Voltage output

Output Signal: 10mV/A

Accuracy and Phase Shift*:

Accuracy:

0.1 to 1A: $\leq 3\%$ Reading $\pm 200\mu\text{V}$

1 to 20A: $\leq 2\%$ Reading $\pm 200\mu\text{V}$

20 to 80A: $\leq 1\%$ Reading

80 to 150A: $\leq 3\%$ Reading

150 to 200A: $\leq 7\%$ Reading

Phase Shift:

0.1 to 1A: Not Specified

1 to 20A: $\leq 3^\circ$

20 to 80A: $\leq 2^\circ$

80 to 150A: $\leq 3^\circ$

150 to 200A: $\leq 4^\circ$

(*Reference conditions: 18°C to 28°C, 20 to 75% RH, external magnetic field <40 A/m, 48 to 65 Hz sine wave, distortion factor less than 1%, no DC component, no external current carrying conductor, test sample centered.)
Load impedance > 1 M Ω .

Frequency Range: 40 to 10kHz

Limit Operating Conditions:

200A permanently to 1kHz;

Derating above 3kHz: 200A x (1/0.333F), F in kHz

Crest Factor:

5 @ 280A peak max with an error (due to CF) of 3%

Working Voltage:

600Vrms

Common Mode Voltage:

600Vrms

Influence of Adjacent Conductor:

< 15mA/A at 50 Hz

Influence of DC on AC signal:

DC Current < 10A, < 10%

Influence of Conductor Position in Jaw:

0.5% of mV output @ 50/60 Hz

Influence of Frequency:

40 Hz to 1 kHz: 5% of mV output
1 kHz to 10 kHz: 15% of mV output

Influence of Load:

< 3% of mA output from 40 Hz to 1 kHz
< 12% of mA output from 1 kHz to 10 kHz

Influence of Temperature:

≤ 200 ppm/°K, or 0.2% of mV output per 10°K

Influence of Humidity (10 - 90% RH):

≤ 0.2% of mV output per 10°K @ 18°C to 28°C

MECHANICAL SPECIFICATIONS**Operating Temperature:**

14° to 131°F (-10° to +55°C)

Storage Temperature:

-40° to 158°F (-40° to +70°C)

Operating Relative Humidity:

10-35°C 85% RH
(without roll-off above 35°C)

Maximum Cable Diameter:

One Ø 0.78" (20mm), bus bar 20 x 5mm

Case Protection:

IP 40 (IEC 529)

Drop Test:

Test per IEC 68-2-32:
1.0m drop on 38 mm of Oak on concrete.

Mechanical Shock:

Test per IEC 68-2-27

Vibration:

Test per IEC 68-2-6

Dimensions:

5.47 x 2.00 x 1.18" (139 x 51 x 30mm)

Weight:

180 g (6.5 oz)

Polycarbonate Material:

Jaws: Polycarbonate with 10% fiberglass charge,
Red UL 94 V0

Case: Polycarbonate 920A Gray

Opening Operations - Life:

> 50,000

Output:

MN352: Two standard safety banana jacks (4mm)

MN353: Double/reinforced insulated 5 ft (1.5m)
lead with safety 4mm banana plug

SAFETY SPECIFICATIONS**Electrical:**

Double insulation or reinforced insulation between the primary or secondary and the outer case of the handle conforms to IEC 1010-2-32.

Common Mode Voltage:

600V Category III
Pollution Degree 2

Dielectric Strength:

5550 V, 50/60 Hz between primary, secondary and the outer case of the handle

Electromagnetic Compatibility:

EN 50081-1 Class B
EN 50082-2 Electrostatic discharge
IEC 1000-4-2
Radiated field IEC 1000-4-3
Fast transients IEC 1000-4-4
Magnetic field at 50/60 Hz IEC 1000-4-8

ORDERING INFORMATION

AC Current Probe MN352 Cat #21116.26

AC Current Probe MN353 Cat #21116.27

Both models include a user manual and a product warranty and registration card.

Accessories:

Leads, set of 2, 5 ft safety
(1000V) for Model MN352..... **Cat #2111.29**

Banana plug adapter
(to non-recessed plug) **Cat #1017.45**

OPERATION

Please make sure that you have already read and fully understand the WARNING section on page 1.

Making Measurements with the AC Current Probe Model MN352/MN353

- Connect the black lead of the current probe to “common” and the red lead to the AC voltage input on your DMM or other voltage-measuring instrument. The AC current probe has an output of 10mV/A. This means that for 200AAC in a conductor around which the probe is clamped, 2VAC will come out of the probe leads to your DMM or instrument. Select the range which corresponds to the measured current. If the current magnitude is unknown, start with the highest range and work down until the appropriate range and resolution are reached. Clamp the probe around the conductor. Take the reading on the meter and multiply it by 100 to obtain the measured current (e.g, 160mV reading = $160 \times 100 = 16,000\text{mA}$ or 16A)
- For best accuracy, avoid if possible, the proximity of other conductors which may create noise.

Tips for Making Precise Measurements

- When using a current probe with a meter, it is important to select the range that provides the best resolution. Failure to do this may result in measurement errors.
- Make sure that probe jaw mating surfaces are free of dust and contamination. Contaminants cause air gaps between the jaws, increasing the phase shift between primary and secondary. It is very critical for power measurement.

MAINTENANCE:

Warning

- For maintenance use only original factory replacement parts.
- To avoid electrical shock, do not attempt to perform any servicing unless you are qualified to do so.
- To avoid electrical shock and/or damage to the instrument, do not get water or other foreign agents into the probe.

Cleaning:

To ensure optimum performance, it is important to keep the probe jaw mating surfaces clean at all times. Failure to do so may result in error in readings. To clean the probe jaws, use very fine sand paper (fine 600) to avoid scratching the jaw, then gently clean with a soft oiled cloth.

REPAIR AND CALIBRATION

You must contact our Service Center for a Customer Service Authorization number (CSA#). This will ensure that when your instrument arrives, it will be tracked and processed promptly. Please write the CSA# on the outside of the shipping container. If the instrument is returned for calibration, we need to know if you want a standard calibration, or a calibration traceable to N.I.S.T. (includes calibration certificate plus recorded calibration data).

Chauvin Arnoux[®], Inc. d.b.a. AEMC[®] Instruments
15 Faraday Drive • Dover, NH 03820 USA

Tel: (800) 945-2362 (Ext. 360)
(603) 749-6434 (Ext. 360)

Fax: (603) 742-2346 or (603) 749-6309

repair@aemc.com

(Or contact your authorized distributor)

Costs for repair, standard calibration, and calibration traceable to N.I.S.T. are available.

NOTE: All customers must obtain a CSA# before returning any instrument.

TECHNICAL AND SALES ASSISTANCE

If you are experiencing any technical problems, or require any assistance with the proper use or application of this instrument, please call our technical hotline:

(800) 343-1391 • (508) 698-2115 • Fax (508) 698-2118

Chauvin Arnoux[®], Inc. d.b.a. AEMC[®] Instruments
techsupport@aemc.com

www.aemc.com